

Engine

Isuzu AJ-4JJ1X Tier 3 turbocharged diesel engine with electronic fuel control, 95 Net HP (71 kW), 3 liter displacement, 4-cylinder, water-cooled, EGR with cooler, air-to-air intercooler, 24-volt system, 50 amp alternator, Emergency Engine Stop, Green Plug oil drain, double element air filter.

SAE net horsepower	95 hp (71 kW) @ 2000 rpm
Displacement	183 cu in (2,999 cc)
Maximum torque.....	265 lbf-ft (359 Nm)
Starter.....	24V-4.0kW
Alternator.....	50 amp
Battery.....	72 amp-hours

Cab and Controls

Cab with a/c and heat with defrost, analog gauge package, illuminated softtouch switches, low-effort controls, control pattern changer, blade control, one-touch idle, safety glass windows, intermittent windshield wiper with washer, polycarbonate roof hatch, sun visor, shockless cab suspension with four fluid mountings, KAB® reclining suspension seat, AM/FM radio, dome light, seat belt, cup holder, storage compartments, floor mat, footrests, cigarette lighter, ashtray, 12-volt outlet, travel alarm, handrail, mirrors. Common key locks, tool box, 70W work light, non-skid surface pads, handrail.

Two selectable working modes, auto-idling system, one-touch decelerator, gate lock safety shutoff.

A/C output.....	13,490 BTU/hr
Heater output.....	12,900 BTU/hr
Sound level (inside cab).....	76.0 dB(A)
Sound level (exterior).....	97.0 dB(A)

Hydraulic System

Open-center system, two variable displacement axial piston pumps and one gear pump for pilot controls, main control valve with one 4-spool valve and one 5-spool valve with auxiliary spool, 1-spool valve for blade and auxiliary, oil cooler, boom and arm holding valves, attachment cushion, o-ring face seals, 6 micron return filter.

Hydraulic Pumps

Maximum flow	2 x 30.9 gpm (2 x 117 l/min)
Pilot pump maximum flow	5.3 gpm (20 l/min)
Blade pump maximum flow	14.3 gpm (54 l/min)

Relief Valve Settings

Boom/arm/bucket.....	4,970 psi (343 bar)
Swing circuit	4,060 psi (280 bar)
Travel circuit	4,970 psi (343 bar)
Blade pump working circuit pressure.....	2,990 psi (206 bar)

Hydraulic Cylinders

	number of cylinders – bore x rod x stroke
Boom.....	2 - 4.1" x 3.0" x 44.1" (105 mm x 75 mm x 1,120 mm)
Arm.....	1 - 4.5" x 3.1" x 43.6" (115 mm x 80 mm x 1,108 mm)
Bucket.....	1 - 3.7" x 2.6" x 34.7" (95 mm x 65 mm x 881 mm)
Blade.....	2 - 4.4" x 2.9" x 9.5" (110 mm x 70 mm x 240 mm)

Hydraulic Oil Filtration

Return filter.....	6 micron
Pilot filter.....	8 micron
Suction screen.....	150 micron



Swing

Fixed-displacement, axial piston swing motor, planetary gear reduction. Mechanical disc brake and ball bearing with internal gear for turntable.

Swing speed.....	0 – 10 rpm
Tail swing.....	4' 10" (1.48 m)
Swing torque	27,044 lbf-ft. (36.7 kN•m)

Undercarriage

X Pattern carbody with 9' 4" (2.85m) LC long undercarriage by 6' 6" (1.99m) track gauge, sealed and strutted track chain, sealed rollers and idlers, two-speed independent hydrostatic travel with compact planetary final drive, disc type brakes, adjustable track tension, swivel guard, 7' 7" (2.32m) hydraulically controlled dozer blade.

Carrier rollers.....	1 per side
Track rollers.....	6 per side
Track link pitch.....	6.75" (171.5 mm)
Shoes.....	43 per side
Shoe width.....	23.6" (600 mm)
Ground pressure	5.22 psi (0.36 Bar)
Ground pressure w/blade.....	5.66 psi (0.39 Bar)

Lubricant and Coolant Capacity

Fuel tank.....	43.59 gallons (165.0 Liters)
Hydraulic tank.....	21.40 gallons (81.0 Liters)
Hydraulic system.....	34.34 gallons (130.0 Liters)
Final drive (per side).....	0.55 gallons (2.1 Liters)
Swing drive.....	0.79 gallons (3.0 Liters)
Engine oil.....	4.54 gallons (17.2 Liters)
Cooling system.....	3.70 gallons (14.0 Liters)

Travel System

Variable-displacement axial piston travel motor, planetary gear reduction final drive, spring-applied hydraulic release disc brake. Max. travel speed..... 1.9 - 3.1 mph (3.1 - 5.0 km/hr)
Drawbar pull..... 25,628 lbf (114 kN)
Gradeability..... 70% (35°)

Attachment

Boom.....	15' 6" (4.73 m)
Available Arms (Excavator)	Digging Force*
• 7' 10" (2.39m).....	14,370 lbf (64 kN)
• 9' 4" (2.85m).....	13,490 lbf (60 kN)

Bucket Digging Force..... 20,170 lbf (90 kN)

*Digging force ratings are based on ISO 6015, "Earthmoving Machinery – Hydraulic Excavators – Tool Forces."

Fuel Usage*

Heavy.....	2.54 gal / hr (9.6 liter / hr)
Average.....	2.22 gal / hr (8.4 liter / hr)
Light.....	1.74 gal / hr (6.6 liter / hr)

*Fuel economy varies widely depending on application. "Heavy" represents nearly continuous operation in tough digging applications in SP Mode. "Light" represents easy digging applications utilizing the machine about 50% of the time in SP Mode.

Operating Weight

Mono Boom Excavator - Working weight with 23.6" (600mm) shoes, 15' 6" (4.73m) boom, 7' 10" (2.39m) arm, 880lb (400kg) bucket, 7,094lb (3,218kg) counterweight
..... 29,762 lbs. (13,500 kg)
with dozer blade..... 31,526 lbs (14,300 kg)

135 Spin Ace® Tier 3 Specifications

Working Ranges

Machine equipped with 15' 6" (4.73 m) boom.		7' 10" Arm (2.39 m)	9' 4" Arm (2.85 m)
A.	Max. digging radius	26' 11" (8.21 m)	28' 1" (8.57 m)
B.	Max. digging radius @ ground level	26' 6" (8.07 m)	27' 8" (8.43 m)
C.	Max. digging depth	17' 11" (5.47 m)	19' 5" (5.93 m)
D.	Max. digging height	30' 6" (9.31 m)	31' 3" (9.52 m)
E.	Max. dumping height	22' 8" (6.91 m)	23' 5" (7.13 m)
F.	Digging depth – 8' (2.44 m) level bottom	17' 3" (5.25 m)	18' 9" (5.72 m)
G.	Bucket wrist angle	178°	178°
H.	Max. vertical wall depth	15' 11" (4.85 m)	16' 8" (5.07 m)

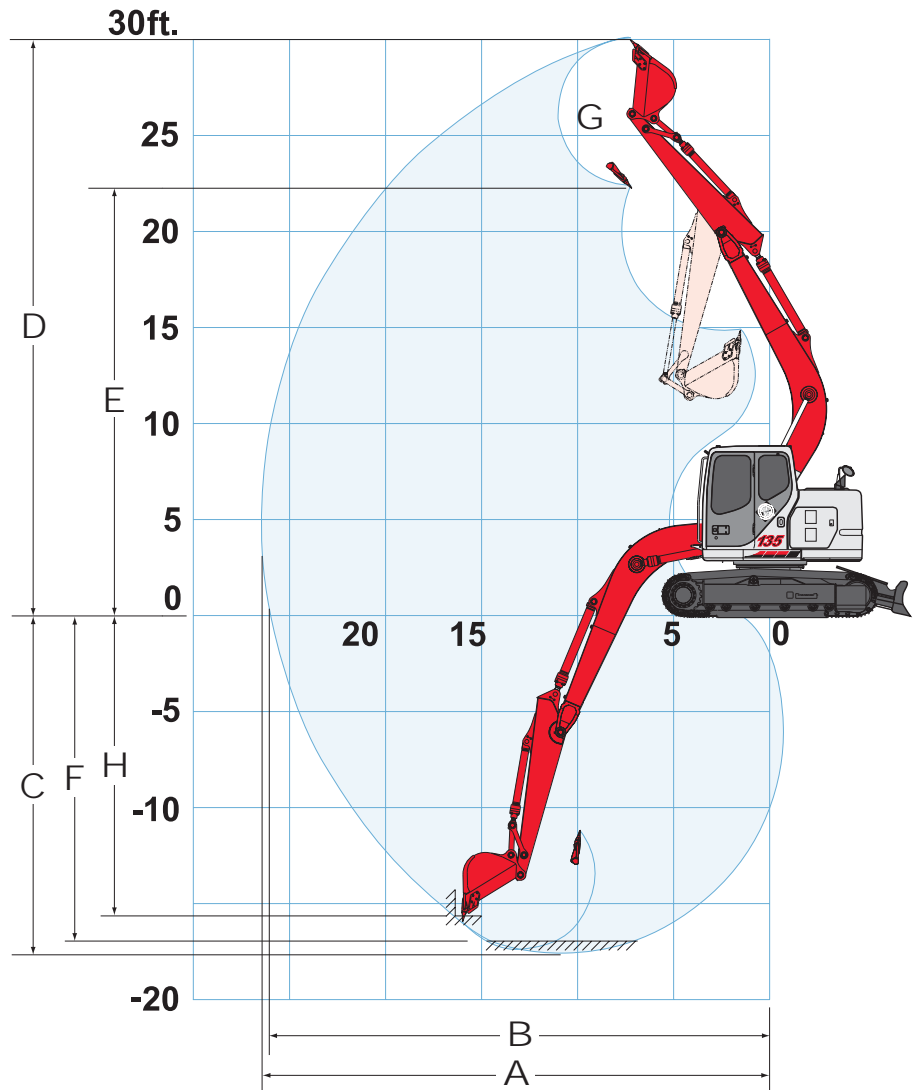

Bucket Sizes

135 MSR

Bucket Type	Capacity	Width Outside Lip	Weight	# Teeth	No Blade		Blade Up	
					7' 10" (2.39 m)	9' 4" (2.85 m)	7' 10" (2.39 m)	9' 4" (2.85 m)
ESCO STDP	.50 yd ³ (.38 m ³)	24" (610 mm)	791 lb. (359 kg)	4	H	H	H	H
	.66 yd ³ (.50 m ³)	30" (762 mm)	889 lb. (403 kg)	4	M	M	H	M
	.82 yd ³ (.63 m ³)	36" (914 mm)	1,007 lb. (457 kg)	5	L	L	M	L
	.98 yd ³ (.75 m ³)	42" (1 067 mm)	1,110 lb. (503 kg)	6	L	N/A	L	N/A
ESCO HDP	.50 yd ³ (.38 m ³)	24" (610 mm)	1,064 lb. (483 kg)	4	H	H	H	H
	.65 yd ³ (.50 m ³)	30" (762 mm)	1,183 lb. (537 kg)	4	M	L	M	M
	.81 yd ³ (.62 m ³)	36" (914 mm)	1,331 lb. (604 kg)	5	L	N/A	L	M
	.97 yd ³ (.74 m ³)	39" (991 mm)	1,390 lb. (631 kg)	5	N/A	N/A	L	L
POWER	.42 yd ³ (.32 m ³)	24" (1 524 mm)	1,225 lb. (556 kg)	4	H	H	H	H
	.55 yd ³ (.42 m ³)	30" (1 676 mm)	1,314 lb. (596 kg)	4	H	M	H	M
	.68 yd ³ (.52 m ³)	36" (1 676 mm)	1,431 lb. (649 kg)	5	L	L	M	L
ESCO DITCH	.86 yd ³ (.66 m ³)	60" (1 524 mm)	970 lb. (440 kg)	0	L	L	L	L
	.96 yd ³ (.73 m ³)	66" (1 676 mm)	1,040 lb. (472 kg)	0	L	N/A	L	N/A

Approval Code For Arm/Bucket Combinations:

- H - Heavy material (up to 3,370 lbs./ yd³)
- M - Medium material (up to 2,700 lbs./ yd³)
- L - Light material (up to 2,020 lbs./ yd³)
- N/A - Not applicable

135 Spin Ace® Tier 3 Specifications

Lifting Capacities 135 Spin Ace®

7' 10" (2.39 m) Arm without blade

15' 6" (4.73 m) Boom and 879 lb. (398 kg) Bucket

Bucket Hook Height		Radius of Load											
		5' 0" (1.52 m)		10' 0" (3.05 m)		15' 0" (4.57 m)		20' 0" (6.10 m)		Cap. at Max. Reach			
		End	Side	End	Side	End	Side	End	Side	End	Side		
+25' 0" (7.62 m)	lbs. kg											3,450* 1 565*	3,450* 1 565*
+20' 0" (6.10 m)	lbs. kg					6,850* 3 107*	6,850* 3 107*					2,950* 1 338*	2,950* 1 338*
+15' 0" (4.57 m)	lbs. kg					8,650* 3 924*	7,250* 3 289	6,150* 2 790	4,350* 1 973			2,800* 1 270*	2,800* 1 270*
+10' 0" (3.05 m)	lbs. kg			14,150* 6 418*	13,400* 6 078	9,800* 4 445	6,800* 3 084	6,000* 2 722	4,200* 1 905			2,800* 1 270*	2,600* 1 179
+5' 0" (1.52 m)	lbs. kg			18,450* 8 369	11,750* 5 330	9,150* 4 150	6,250* 2 835	5,750* 2 608	3,950* 1 792			3,000* 1 361*	2,450* 1 111
Ground Line	lbs. kg			17,200* 7 802	10,800* 4 899	8,700* 3 946	5,800* 2 631	5,550* 2 517	3,750* 1 701			3,350* 1 520*	2,550* 1 157
-5' 0" (1.52 m)	lbs. kg	11,400* 5 171*	11,400* 5 171*	17,150* 7 779	10,700* 4 853	8,450* 3 833	5,600* 2 540	5,400* 2 449	3,650* 1 656			4,000* 1 814*	2,950* 1 338
-10' 0" (3.05 m)	lbs. kg	18,350* 8 323*	18,350* 8 323*	16,250* 7 371*	10,900* 4 944	8,500* 3 856	5,650* 2 563					5,450* 2 472*	4,050* 1 837
-15' 0" (4.57 m)	lbs. kg			9,550* 4 332*	9,550* 4 332*								

9' 4" (2.85 m) Arm without blade

15' 6" (4.73 m) Boom and 747 lb. (338 kg) Bucket

Bucket Hook Height		Radius of Load													
		5' 0" (1.52 m)		10' 0" (3.05 m)		15' 0" (4.57 m)		20' 0" (6.10 m)		25' 0" (7.62 m)		Cap. at Max. Reach			
		End	Side	End	Side	End	Side	End	Side	End	Side	End	Side		
+25' 0" (7.62 m)	lbs. kg													3,750* 1 701*	3,750* 1 701*
+20' 0" (6.10 m)	lbs. kg					6,750* 3 062*	6,750* 3 062*							3,350* 1 520*	3,350* 1 520*
+15' 0" (4.57 m)	lbs. kg					7,600* 3 447*	7,350* 3 334	6,300* 2 858	4,450* 2 018					3,200* 1 451*	2,800* 1 270
+10' 0" (3.05 m)	lbs. kg			11,700* 5 307*	11,700* 5 307*	9,550* 4 332*	7,000* 3 175	6,100* 2 767	4,300* 1 950					3,300* 1 497*	2,400* 1 089
+5' 0" (1.52 m)	lbs. kg			17,750* 8 051*	12,150* 5 511	9,300* 4 218	6,400* 2 903	5,800* 2 631	4,000* 1 814	4,000* 1 814	2,700* 1 225			3,450* 1 565	2,300* 1 043
Ground Line	lbs. kg			17,450* 7 915	10,900* 4 944	8,750* 3 969	5,850* 2 654	5,550* 2 517	3,750* 1 701	3,900* 1 769	2,600* 1 179			3,550* 1 610	2,350* 1 066
-5' 0" (1.52 m)	lbs. kg	10,800* 4 899*	10,800* 4 899*	17,000* 7 711	10,600* 4 808	8,450* 3 833	5,600* 2 540	5,400* 2 449	3,600* 1 633					4,000* 1 814	2,650* 1 202
-10' 0" (3.05 m)	lbs. kg	16,550* 7 507*	16,550* 7 507*	17,000* 7 711	10,700* 4 853	8,400* 3 810	5,550* 2 517	5,400* 2 449	3,600* 1 633					5,200* 2 359	3,500* 1 588
-15' 0" (4.57 m)	lbs. kg	18,600* 8 437*	18,600* 8 437*	12,050* 5 466*	10,950* 4 967	7,900* 3 583*	5,800* 2 631								

Notes: Excavator lifting capacities

- Lifting capacities shown should not be exceeded. Weight of all lifting accessories must be deducted from the above lifting capacities.
- Lifting capacities are based on machine standing on firm, uniform supporting surface. User must make allowances for job conditions such as soft or uneven ground.
- Lifting capacities shown do not exceed 75% of minimum tipping loads or 87% of hydraulic capacities. Capacities marked with an asterisk (*) are limited by hydraulic capacities.
- Least stable position is over the side.
- Operator should be fully acquainted with the Operator's Manual & Operating Safety Booklet, furnished by LBX before operating the machine.
- Capacities apply only to the machine as originally manufactured and normally equipped by LBX Company LLC.
- Lift capacity ratings are based on SAE J/ISO 10567, "Earthmoving Machinery – Hydraulic Excavators – Lift Capacity".

135 Spin Ace® Tier 3 Specifications

Dimensions

Dimensions - 7' 10" (2.39 m) arm

A.	Overall length.....	23' 9" (7.24 m)
	Overall length w/blade	25' 5" (7.76 m)
B.	Overall width.....	7' 11" (2.42 m)
C.	Overall height.....	9' 0" (2.75 m)
D.	Distance between sprocket and idler.....	9' 2" (2.79 m)
E.	Overall length of crawler.....	11' 4" (3.51 m)
E1.	Overall length of crawler and blade....	13' 2" (4.02 m)
F.	Overall width of crawler with std. shoe ...	8' 6" (2.59 m)
G.	Track gauge	6' 6" (1.99 m)
H.	Min. ground clearance	1' 5" (435 mm)
I.	Shoe width	23.6" (600 mm)
J.	Tail swing radius	4' 10" (1.48 m)
K.	Cab height	9' 0" (2.75 m)
L.	Overall width of upperstructure	7' 11" (2.42 m)

Dimensions - 9' 4" (2.85 m) arm

A.	Overall length.....	23' 9" (7.23 m)
	Overall length w/blade	25' 4" (7.73 m)
C.	Overall height.....	9' 0" (2.75 m)

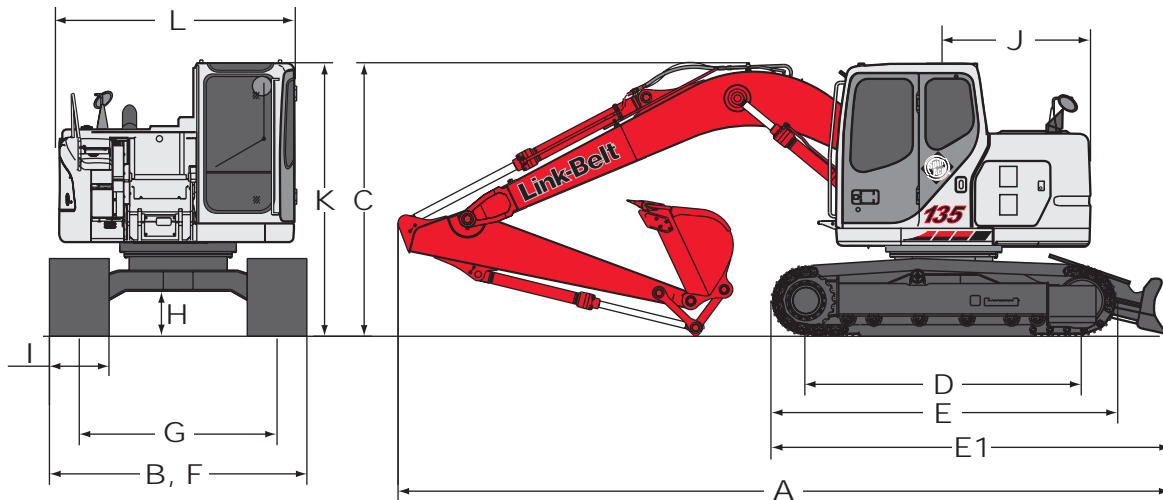

Standard Equipment

- Work Modes
 - Normal
 - Economy
- Control Pattern Selector Valve
- One-touch decelerator
- Integral cylinder cushioning
- Cushioned attachment
- Swing cushion valve
- Auxiliary valve spool
- Travel alarm
- Auto power swing
- Two speed travel w/auto shift
- Low noise/low vibration cab floating on 4 fluid filled mounts
- Sliding/reclining, suspension cloth upholstered seat with adjustable arm rests and lumbar support, seat belt
- Analog gauge package
- Heater and air conditioner

- Rear view mirrors
- Two work lights, cab and boom
- Horn, interior lighting, AM/FM STEREO radio, clock, floor mat, cigarette lighter
- 12 volt accessory outlet for cell phones/ audio extras
- Safety glass windows with windshield wiper and washer
- Gate lock lever (hydraulic lockout device)
- Vandalism locks
- Common key for cab & house doors, engine hood, and fuel cap
- Upper and lower undercovers
- Chrome plated boom foot pin with brass bushing
- Chrome plated boom to arm connection pin with brass bushing
- 23.6" (600 mm) 3-bar grouser shoes
- 7,094 lb. (3 218 kg) Counterweight

Options

- Arms -
 - 7' 10" (2.39 m)
 - 9' 4" (2.85 m)
- 27.5" (700 mm) 3-bar grouser shoes
- 19.7" (500 mm) rubber track (individual shoes bolting to standard rail)
- Bolt-on rubber pads (bolt to steel shoes)
- Dozer blade (factory install)
- Auxiliary Hydraulics
 - Single Acting
 - Multi-Function
 - Thumb
- Hose Burst Check Valves
- Couplers (field install)
 - Esco Multi-Pin Grabber
- Thumbs (field install)
 - Universal rigid
 - Hydraulic non-link
 - Hydraulic non-link (for coupler)
 - Hydraulic link (for coupler)



LBX Company is the proud maker of quality Link-Belt excavators and is located in Lexington, KY.



Litho in USA 1/09 #LBX2159 (Supercedes LBX2139)

© LBX and © Link-Belt are registered trademarks. Copyright 2009. All rights reserved. We are constantly improving our products and therefore reserve the right to change designs and specifications.